

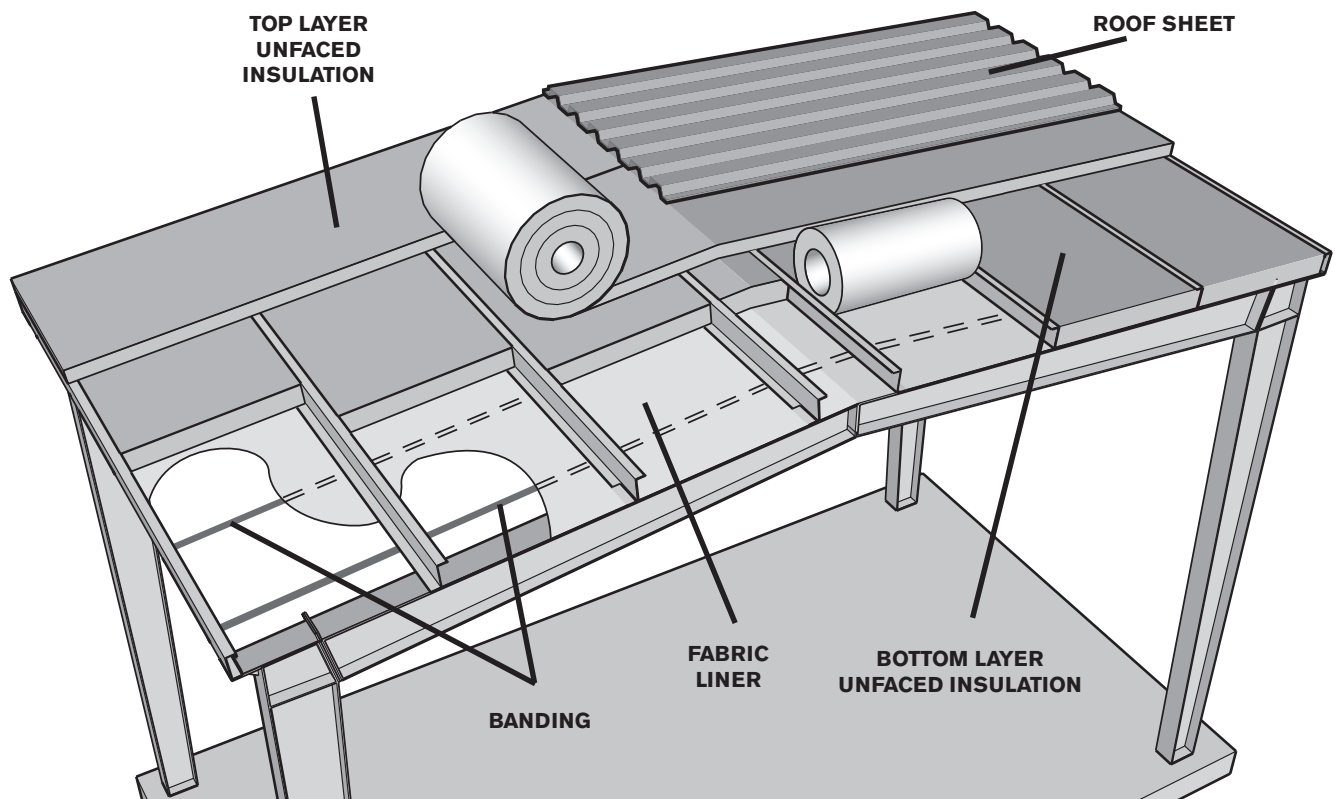

OptiLiner® Banded Liner System Roof Installation Instructions



General

Introduction

The OptiLiner® Banded Liner System is designed to provide maximum thermal performance in pre-engineered metal buildings using Owens Corning metal building insulation. In addition to excellent thermal performance, this system offers outstanding acoustics, finished appearance and a brighter interior.

Safety Considerations

When installed in strict compliance with the following Bi-Directional Banding instructions, OptiLiner meets the requirements of OSHA Standard 29 CFR 1926.754(e) (3)(i) for leading edge fall prevention. Any deviation from these installation instructions or substitution of any original components will nullify compliance with the OSHA standard. Other means of fall protection such as perimeter safety, or guide lines, must be used at all times during roofing while using this system. The use of OptiLiner Banded Liner System is only part of the overall site safety plan for the construction site.

Caution: Banding has sharp edges. Use caution when handling. Wear cut proof gloves.

Required Personal Protective Equipment: Safety glasses, cut proof gloves, long sleeve loose fitting clothing (for insulation installation)

Before You Start

- Open pallets and packaging to ensure complete order was received
- Review drawings to ensure each custom made fabric panel is installed in the appropriate area
- Obtain necessary rake angle for your building type
- Assemble appropriate equipment and tools
- Assure weather is appropriate to begin installation

Materials List

- Banding
- Fabric panels
- Fasteners
- Adhesive and/or double faced tape
- Insulation per specification
- Patch tape (if required)

Equipment and Tools Required

- Man lift/scissor lift/fall protection
- Screw gun
- Tape measure
- Razor knife
- Tin snips
- Iron pipe for banding dispenser
- Safety glasses
- Cut proof gloves
- Locking clamps
- Paint brushes
- Banding dispenser

Installation

Banding Schedule

Traverse Banding Perpendicular to Purlins.

1. Determine the width of the bay and refer to Table 1 for number of bands required.

Table 1

Bay Width (feet)	# Bands for Main Area	# Bands 8 inches from Rafter	Total # of Bands for Bay
15-16	3	2	5
17-20	4	2	6
21-24	5	2	7
25-28	6	2	8
29-32	7	2	9
33-36	8	2	10
37-40	9	2	11
41-42	10	2	12

2. Divide the bay into equal increments for installing main area banding 48 inches on center or less.
3. Locate one band 8 inches off each rafter in addition to the above banding.

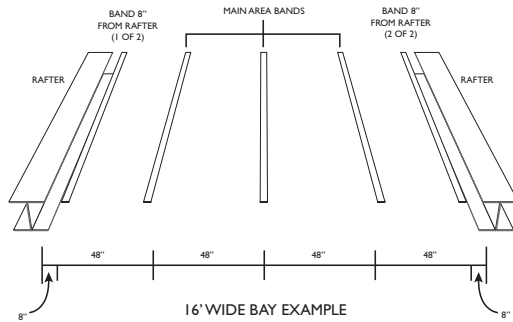

4. Set-up rolls of steel band on the supplied dispenser to be dispensed perpendicular to purlins.
5. Cut bands to reach from eave-to-eave while accounting for roof pitch. Add one foot to each band for handling and fastening (refer to erection drawings).
6. Fasten one end of each traverse band to the bottom of sidewall eave strut using one fastener through the center of the eave strut.

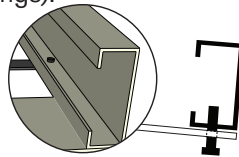

Eave Attachment

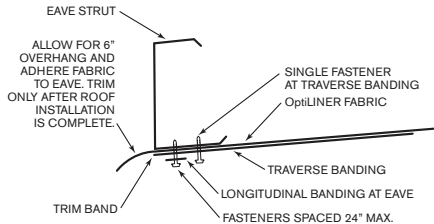

Fabric Splice

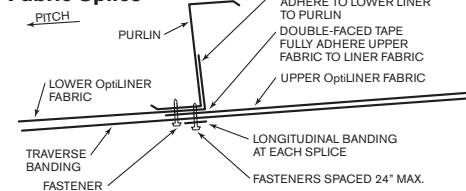

7. Pull each band hand tight to each ridge purlin and fasten with supplied screws. Finally pull each band hand tight to opposite eave strut and fasten.

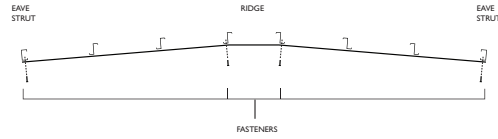

Note: If necessary, use a longitudinal band from end wall to end wall every 25 feet for traverse banding support during installation. Two longitudinal bands may also be used in the ridge area to provide additional support for fabric deployment. Remove longitudinal bands when complete.

8. Sample final banding pattern.

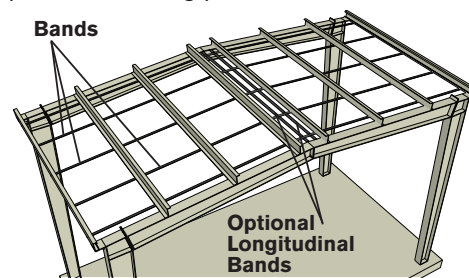

Fabric Placement

Each Fabric Panel Sized and Fabricated For A Specific Bay

1. Select the fabric designated for the bay in which you are working per supplied drawings.
2. Unroll fabric across top of ridge purlin(s).
3. Place the fabric on the steel straps in the ridge purlin space extending from rafter to rafter (see image top of next column).
4. Remove all screws from one ridge purlin.

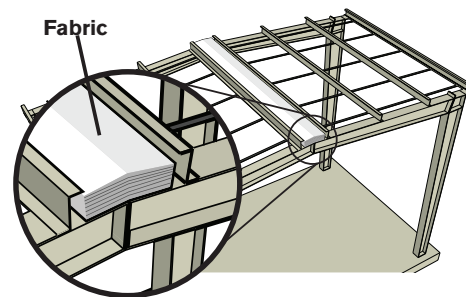
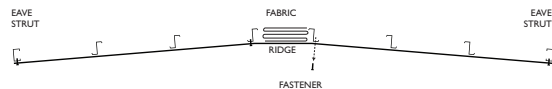

5. Feed edge of the fabric under the purlins and on top of the strapping. Complete one half of the bay at a time.

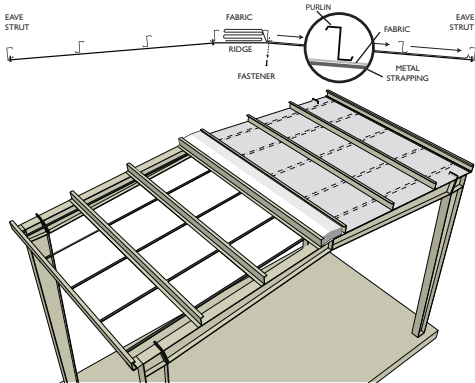

6. Continue pulling fabric to the eave strut, squaring with rafters and eave.
7. Clamp the fabric at the outer corners of the bay at eave strut and rafter intersection.

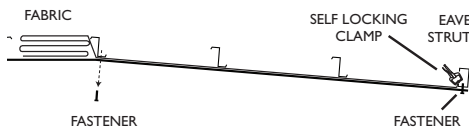

Note: Include enough fabric to cover the underside of the eave strut.

8. Work fabric from the eave strut smoothing the fabric in each purlin space, back to the ridge. Cut around any penetrations and insure proper seal with provided patch tape.
9. Using supplied fasteners, secure cross bands and fabric to bottom of purlins, working the excess fabric to the ridge and to rafter. Re-attach ridge purlin fasteners.
10. Notch the fabric in a "T" pattern to fit neatly around each purlin at the rafter.

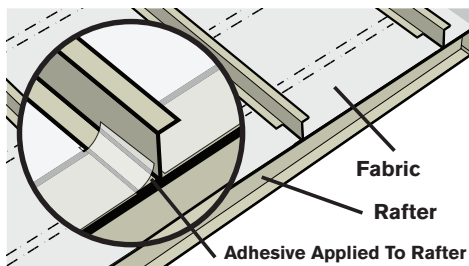

11. Using the supplied adhesive or double faced tape, attach the fabric to the tops of the rafters and sides of purlins.
12. Remove traverse band fasteners at opposite side ridge purlin. Begin feeding the fabric to the opposite eave and repeat steps 5 through 11.
13. Remove eave fasteners, apply adhesive or double faced tape to under side of eave, attach fabric between eave and band and reattach fastener.

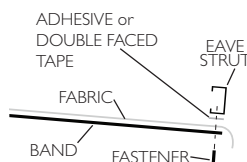

Insulation Installation

1. First layer of unfaced fiberglass insulation is rolled out between the purlins to completely fill the full width of the cavity.

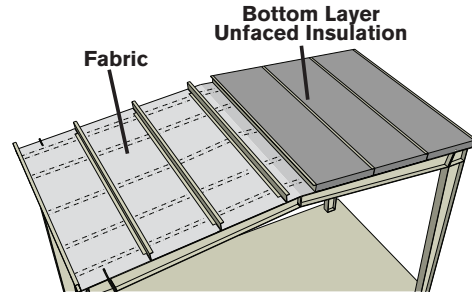

2. Cut around bridging and bracing to allow for full recovery of insulation and butt edges to eliminate gaps or voids.

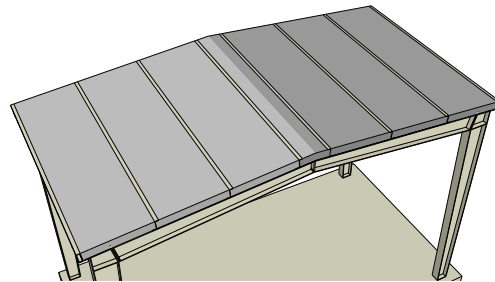

3. Install the second layer of insulation perpendicular and over the top of purlins. Butt edges of each roll to eliminate gaps.

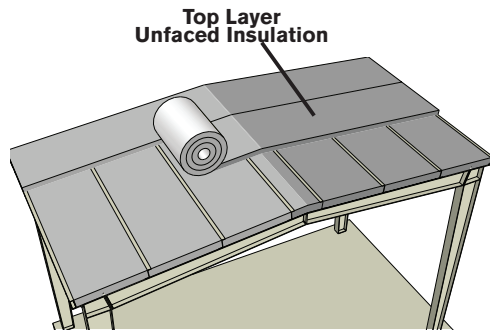

4. Complete by installing specified roofing components.

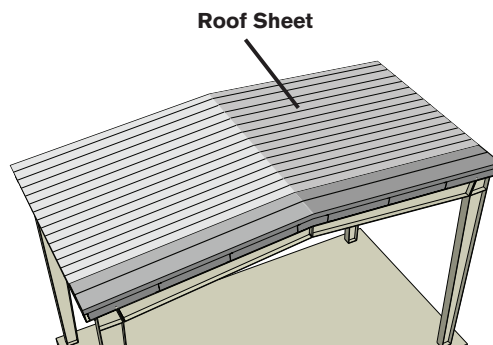

Optional Brace Clip Installation

1. The use of brace clips and or flush mount flanges may allow for mounting of knee bracing to the bottom of the purlins in a roof structure. Brace clips or flush mount flange bracing shall only be used when approved in writing by the building manufacturer. Contact the building manufacturer for details on the availability of brace clips or flush mount flange bracing.

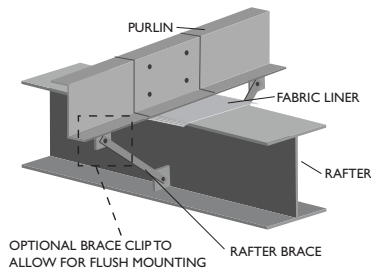

Note: Throughout the installation process insure all fabric edges are sealed properly to adjacent surfaces to maintain vapor barrier integrity.